



ENVASES SANZ BELDA, S.L.

Tel.: 34 96 236 02 32 - calidad@envasesanzbelda.es - www.envasesanzbelda.es
Pol. Ind. San José. Avda, Valencia, parc. 7 - Apdo. de Correos 46 - 46812 Aiello de Malferit, Valencia. (España)



Technical comercial data

E-5.5-UN T.E-5.5

Serie ELEGANCE – Versión 07-02-2024
Approved UN 1H2/Y5.5/S Group II and III solids with inner bag,
marked with a danger triangle for blind people.

TECHNICAL DATA:

Material:	PP copolymer of first quality.
Colours:	White standard. Consult for other colours.
Useful Volume:	5.5 litres
Volume to the edge:	6.5 litres
Weight of the bucket:	203 g. approx.
Weight of the lid:	71 g. approx.
Weight of the handle (plastic):	8 g. approx.
Total Weight:	282 g. approx.
Decorative surface flat inks:	127 x 637 mm (height x perimeter)
Design surface photographic finish:	135 x 655 mm (height x perimeter)



MEASUREMENTS:

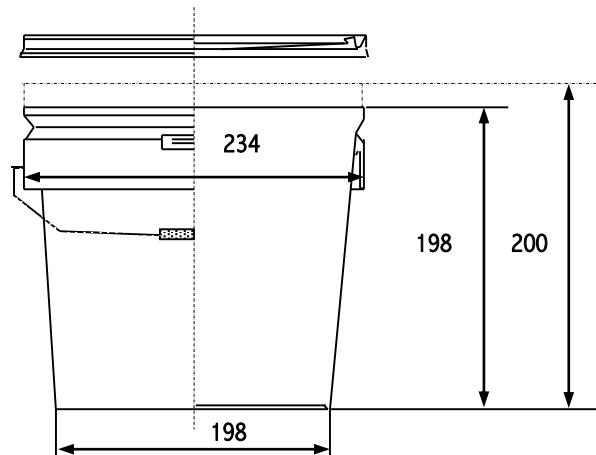

Measurements in millimetres

GROUPING OF TRANSPORT:

Buckets:	600 buckets per pallet
Pallet dimensions:	1180 x 950 x 1140 (see drawing)
Lids:	150 lids per box, this serves as a packaging of transportation
Box dimension:	480 x 250 x 960

